

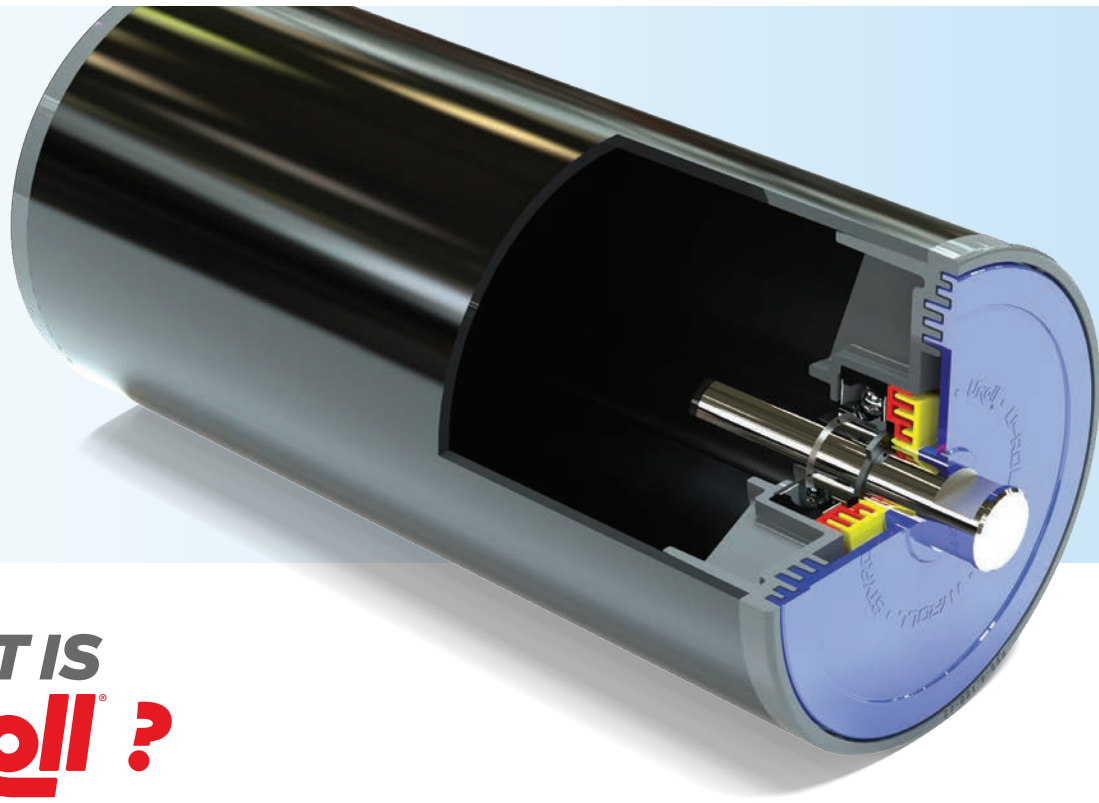

**THE ANTI BLOCK
ROLLER
TECHNOLOGY**

URoll[®]
CONVEYOR ROLLER



WHAT IS **URoll** ?

MISSION

Fabrication of top quality, tailor-made conveyor rollers that meet our clients demands. Listening and advising where need be to ensure that our customers experience with us be as simple as it is efficient, allowing them to bring to reality their projects at a competitive price while respecting our commitments.

VISION

To become a major player in the fabrication of conveyor rollers in quantity as well as in quality thanks to our unique products.

TEAM

Driven by a young and dynamic team that has been working in this field for over 10 years now, we continue to increase our productivity thanks to our work methods and processes. Motivated by what we have already accomplished, we're betting on our experience to increase our production without compromising on quality.

NORMS

All of our conveyor belt structures comply to CEMA (Conveyor Equipment Manufacturers Association) standards. Design and fabrication technology ensures longevity, reliability and superior performance.



THE ANTI BLOCK ROLLER

URoll
CONVEYOR ROLLER

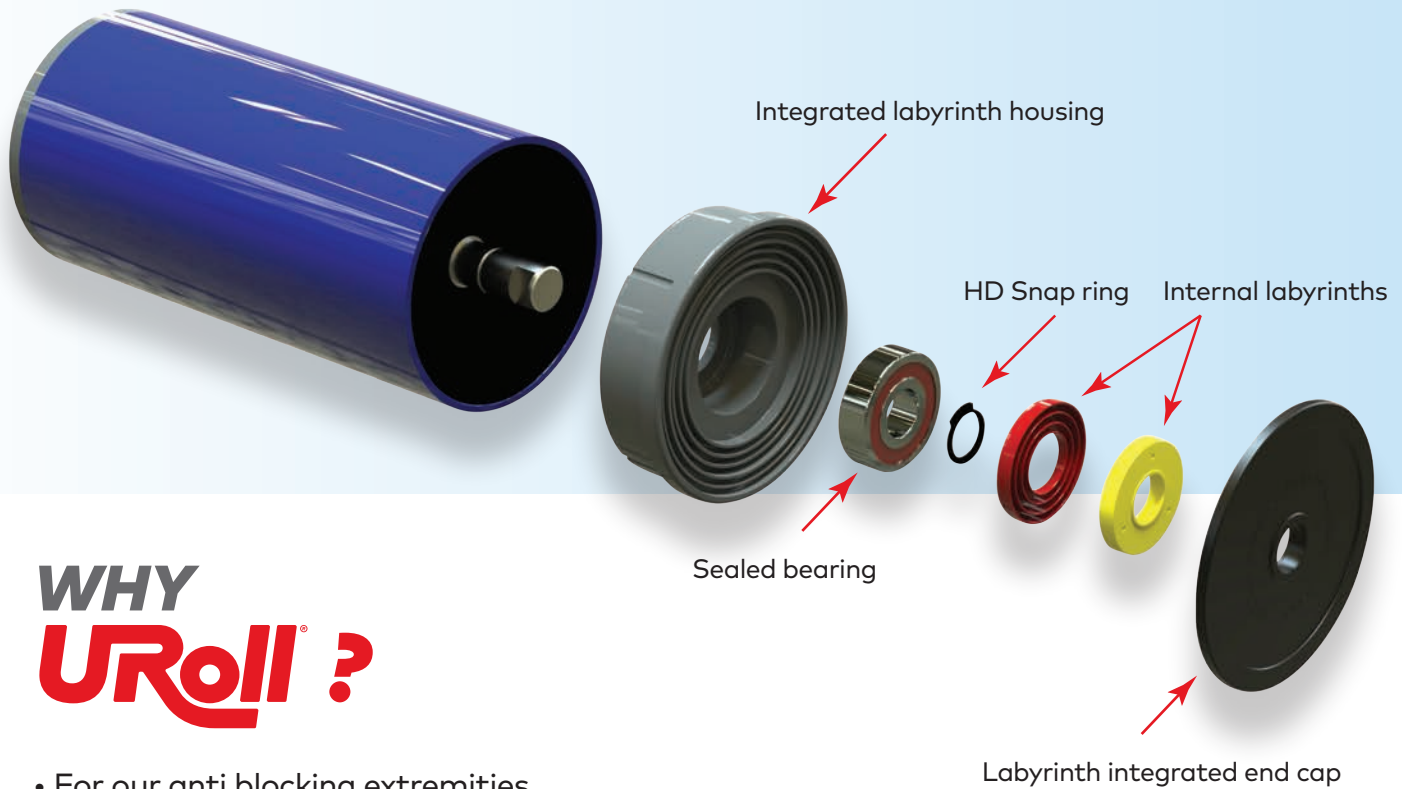

WHY URoll?

- For our anti blocking extremities
- For our 8 labyrinth sealing
- For our superior quality
- For our corrosion resistance
- For our abrasion resistance
- For our lightweight construction
- For noise reduction
- For its balance
- For its versatility
- For the custom-made product
- For cost effectiveness
- For energy effectiveness
- For anti build up
- For our diverse product line
- For increased conveyor belt life
- For reduced shut down time

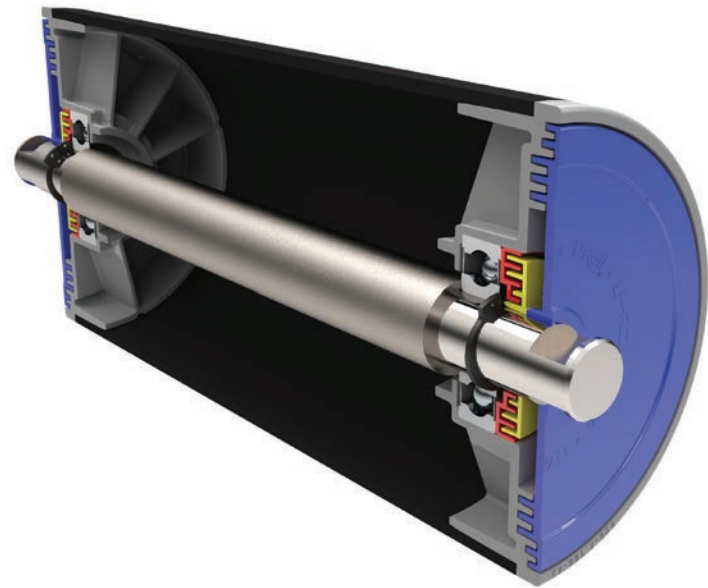

ADVANTAGES

URoll
CONVEYOR ROLLER

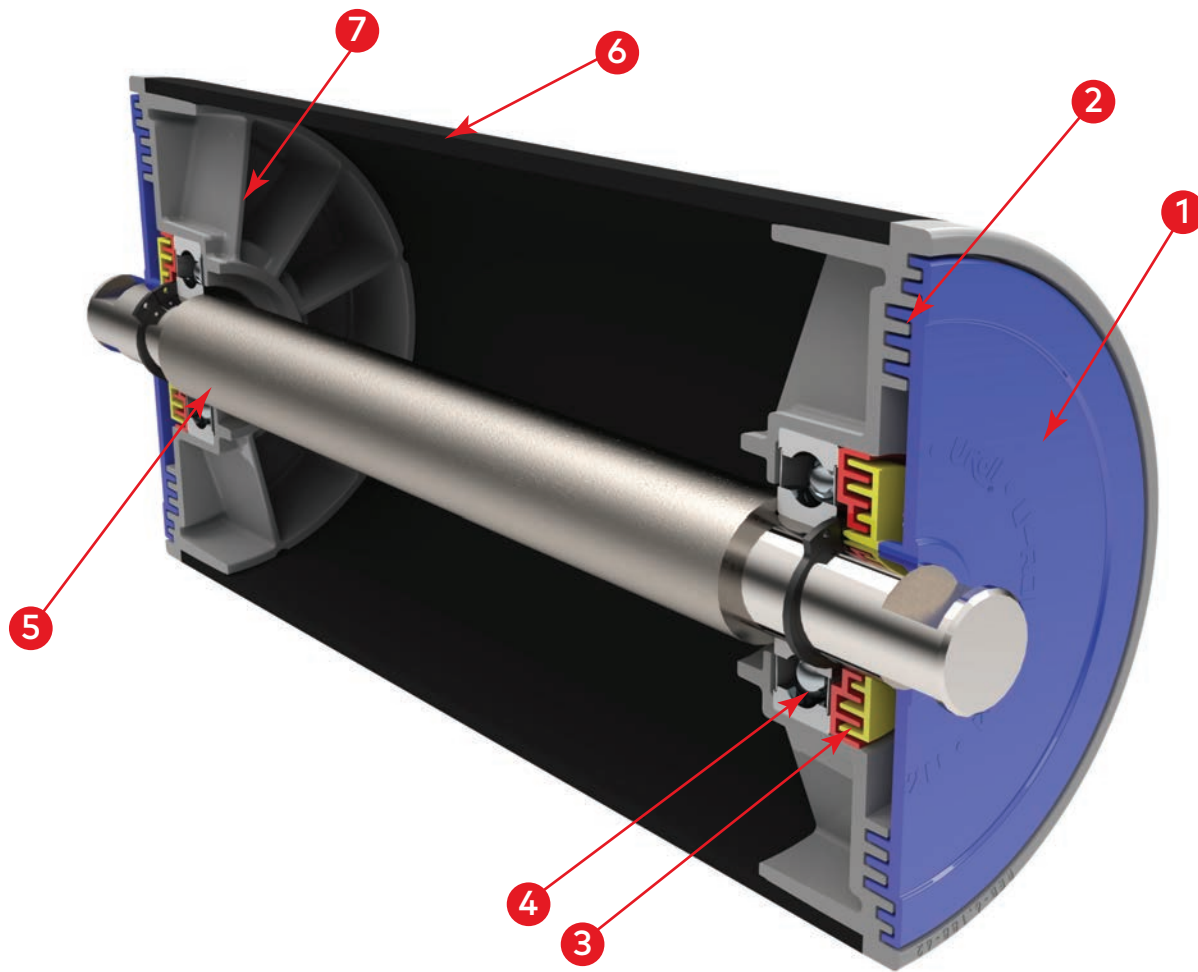

LEGEND

- 1 End cap is motionless which prevents roller from jamming due to accumulation of debris
- 2 End cap labyrinth has 5 baffles for increased contamination prevention
- 3 Internal labyrinth ensures a double protection with an additional 3 baffles against contaminants
- 4 Sealed ball bearings for increased longevity
- 5 Oversized steel shaft which is shouldered to reduce deflection
- 6 Steel tubes in 1/8" – 3/16" – 1/4" thickness available
- 7 High load capacity nylon bearing housing

THE ROLLER STYROLL®

URoll
CONVEYOR ROLLER

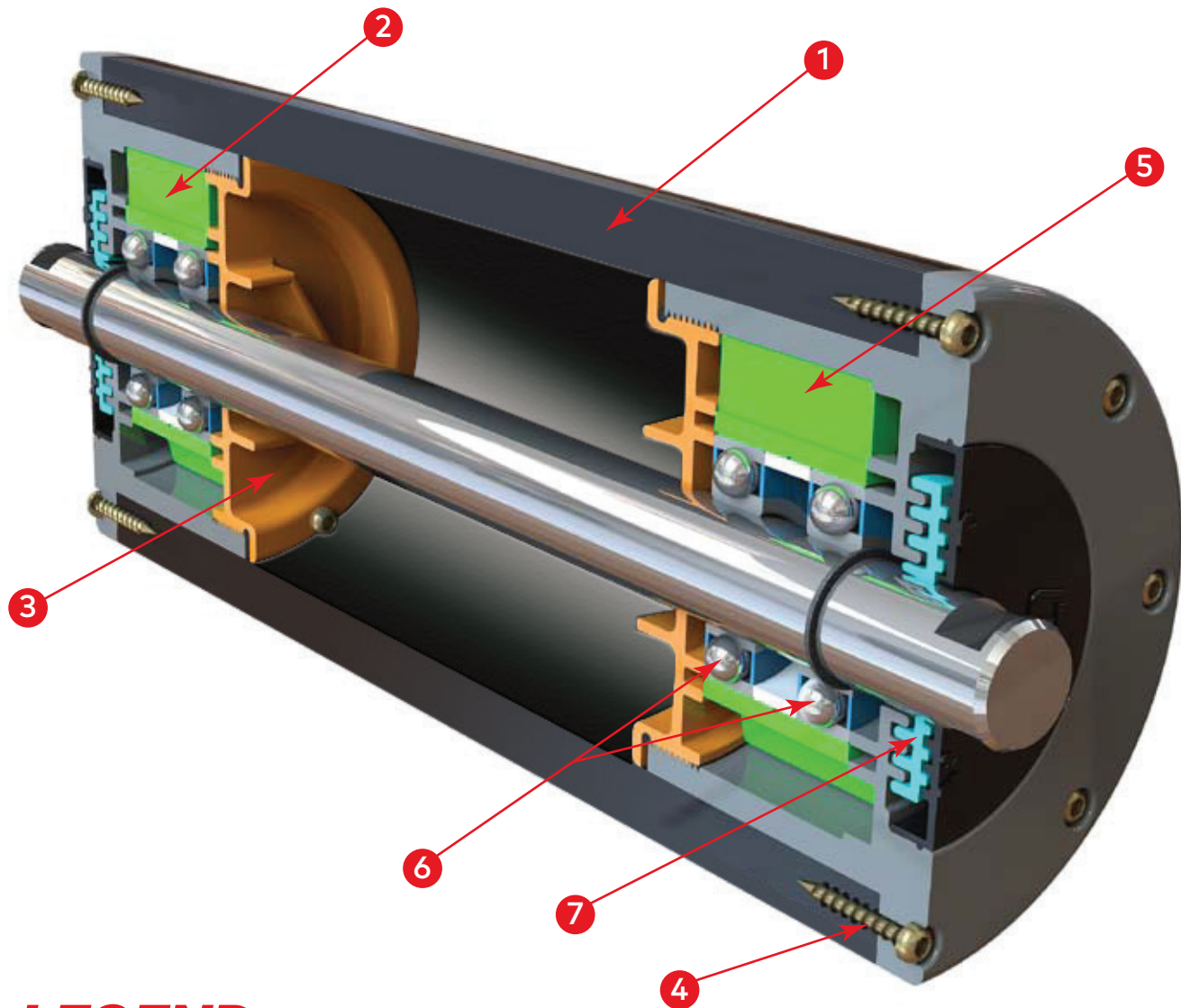

LEGEND

- 1 HDPE or nylon tubing for increased weight reduction
- 2 Impact absorbing and anti vibration ring
- 3 Bearing adjustment screw
- 4 Torque locking stainless steel screw fasteners
- 5 Spacer allowing for large variety of bearings
- 6 4 ball bearing option for longer life
- 7 Precision adjusted 6 baffle labyrinth to better trap contaminants

THE ROLLER HYROLL® / NYROLL®

URoll
CONVEYOR ROLLER

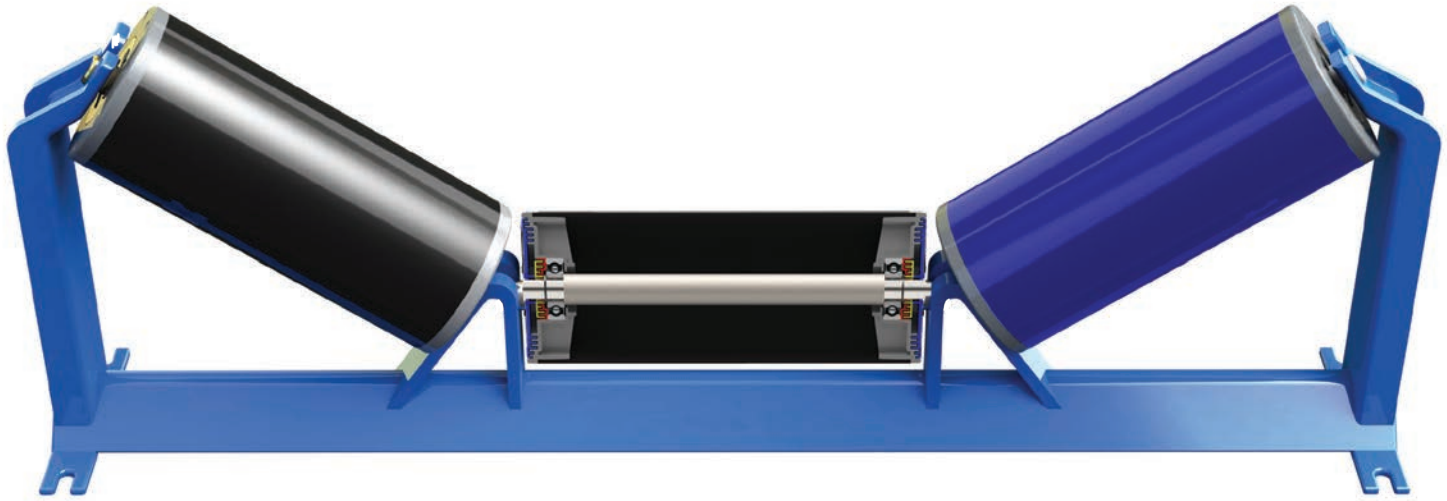

URoll

THE ULTIMATE PRECISION ROLLER

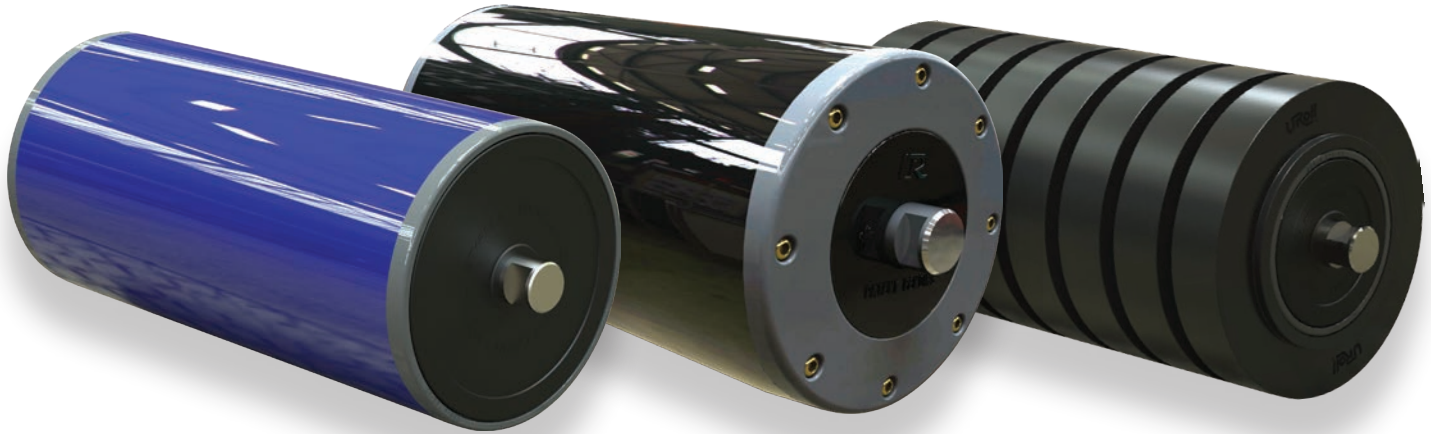

STYROLL®

HYROLL®

IMPACT

TYPICAL APPLICATIONS

INDUSTRIAL SECTORS

- Quarry
- Cement Plant
- Chemical Products Industries
- Sawmill
- Maritime transport (Ports and Ships)
- Electrical Power Stations
- Bulk Handling
- Mining Industries
- Pulp and Paper

APPLICATIONS

URoll
CONVEYOR ROLLER

URoll[®]

RETROFIT SPECIALIST

GET A QUOTE WITHOUT DELAY!

Send your request to email
sales@u-roll.com
or call us at
1 844 728-0035

URoll RETROFIT SPECIALIST

URoll[®]
CONVEYOR ROLLER

URock and URoll!



198 rue Olivier
Issoudun (Québec)
Canada G0S 1L0

Tel: 418-728-0035
Toll free: 1-844-728-0035
u-roll.com

